

LED HUB.Nova



CUSTOM DESIGNED AUSTRALIAN OPTICS
LOWEST ENERGY COMPLIANT PEDESTRIAN
LUMINAIRE IN AUSTRALIA

The NOVA by HUB is a high performance Australian standard compliant residential luminaire. The NOVA utilises the latest in high efficiency Cree LED's with optics designed specifically for Australian streets. Manufactured and tested to the highest international standards. Both optical and gear compartment comply with IP66 and with an overall weight of less than 4kg. With the lowest power consumption in Australia this residential Street Light has been developed to ensure maximum compliance for the lowest cost both capital and operational.

Mains connection:

Class I/II insulation
drawing 220-240V AC
50/60Hz with terminal
3-pole max 2.5mm².

Lamps: LED

Weight (kg): 4kg

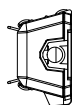
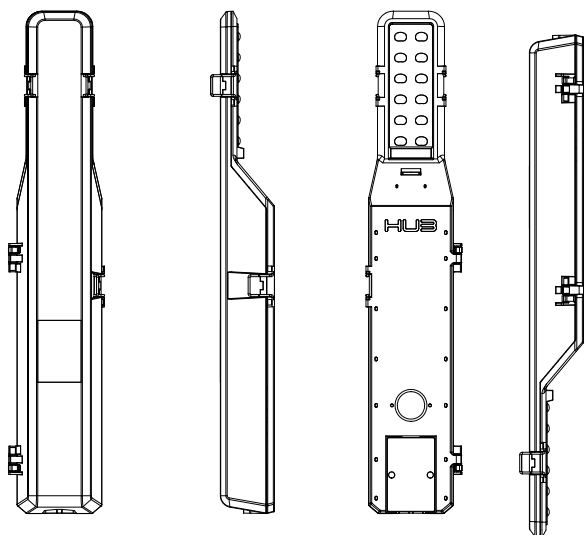
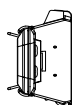

LED HUB.Nova



Key features

CREE High Efficiency chips > 180lm/W

Custom designed Optics providing full AS1158

Lowest Power Pedestrian Light in Australia

Smart control ready

Manufactured to European and Australian standards

Construction

Cast aluminium

Stainless 316 grade stainless

Gaskets neutral cured extruded silicone

Corrosion resistant polyester powder coat available

Dimensions

HUB.Nova	Length	Width	Height	Weight
Dimensions (mm)	599,5	120,4	69,5	4 kg

Electrical and Gear

Total System Wattage <15W, 133 lm/W

Class I, 220.240V, AC, 50/60Hz.

Maintenance

Long life (70,000-100,000hrs) L80 B10

High operating temperatures (-30° to 50°C)

Replaceable/upgradeable Modules

Compliance

AS/NZS 1158.3.1

AS/NZS 1158.6

IEC 60598

IK 08

IP66

Control option

No PE control

D2 PE control

3 pin, 5 pin, 7 pin Nema Control (Smart City compatible)

