

S103 Bin (60L)

Specifications

Stainless steel (304) side panels and door with gloss-white laminate composite insert panels. Cast aluminium (A356) rim and powder-coated cast aluminium chute.

Sub-surface mounted.

Dimensions

L 550mm W 550mm H 850mm

Semi-Bespoke

This piece can be customised to suit your specific needs. Please contact us to discuss the possibilities.



FRONT VIEW

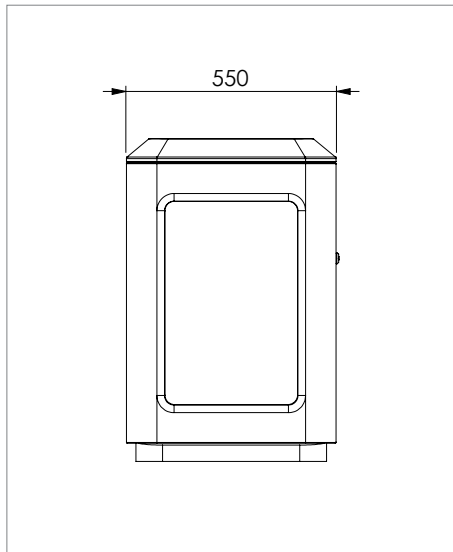

SIDE VIEW

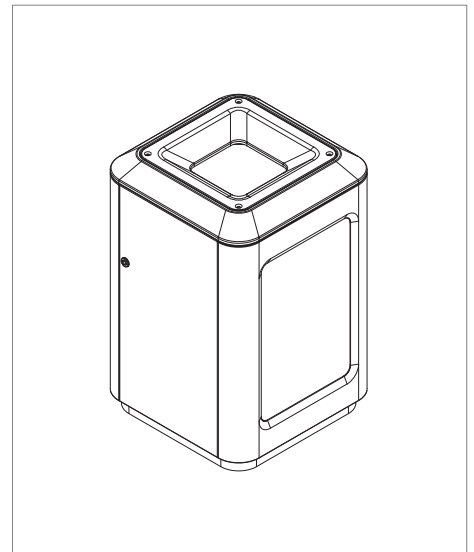

PICTORIAL VIEW

Standard Specifications

Components	Material	Grade	Process	Finish	Colour
Top Rim	Aluminium	A356 or equiv.	Sand Cast	Satin Polish	Raw
Chute	Aluminium	A356 or equiv.	Sand Cast	Bead Blast/Powder Coat	Black
Side Panels	S/S	304	Fabricated	Linish #4/Electro-polish	-
Panel Insert	Aluminium Composite Sheet	-	-	Pre-finished	White
Door	S/S	304	Fabricated	Linish #4/Electro-polish	-
Lock	1/4 turn cam lock, square drive 3 16				
Fixings	S/S	304	-	-	Raw